

FUEL SYSTEM COMPONENTS

4-9-2010

Cost and non-availability drives one to improvise one way or another to find new solutions to apply modern technology to yesterday's engineering and to restore some of those items one usually would replace! The concepts presented on this page are from folks I've encountered in my travels. The new solutions deal with Fuel System Controls, the 3-way fuel cock and the fuel filter assembly. The contributor, Jacob Rupp, claims the solutions have worked well for him for several years now. Sincere and dedicated collectors like Jacob have the grace to allow me to share them with you for your use in bringing that Deere back to life! As other ideas and concepts surface, they too will be presented for your review, choice and use if you like what you see. All I have managed to do thus far is present their data to you. You are also encouraged to experiment and to share if you find something of value in the way of bring new life to old iron!

New Life for the 3-Way Fuel Cock

The two most persistent problems with this valve over the years is fuel leaking and being difficult to operate. Extended use under these conditions oftentimes results in a glazing on the valve cylinder walls which can be removed very easily with ever so gentle use of a fine jewelers rouge which will polish brass. Some have tried valve-grinding compound and found it to be a little too course, and still others have tried various tools such as fine Emory cloth of 1400 grit sandpaper -- again, with limited success.

TIP -- If you find this unit is frozen up, remove the brass packing nut washer and packing, reinstall the packing nut, and subject the unit to some serious heat. Even a stint on the hot BBQ pit will work, and when it has cooled down, the parts should separate with ease.



The Parts of the 3-Way Fuel Cock (Minus the golf tee!)

To combat leakage at the packing nut, most renew the D2122R packing. But eventually, the packing will dry or shrink, but its cost is not a major factor. Modern fuels seem more difficult to control, and before you know it, you are applying more pressure on the packing by tightening the packing nut.

An alternate solution is presented using O-Rings. The drawing below provides the detail you need to incorporate what one might call the "Ultimate" answer. The shaft section of the 3-way fuel cock is machined to receive two O-Rings these for "sealing," and is followed by the D2122R packing for "tension." See drawing for technical details.

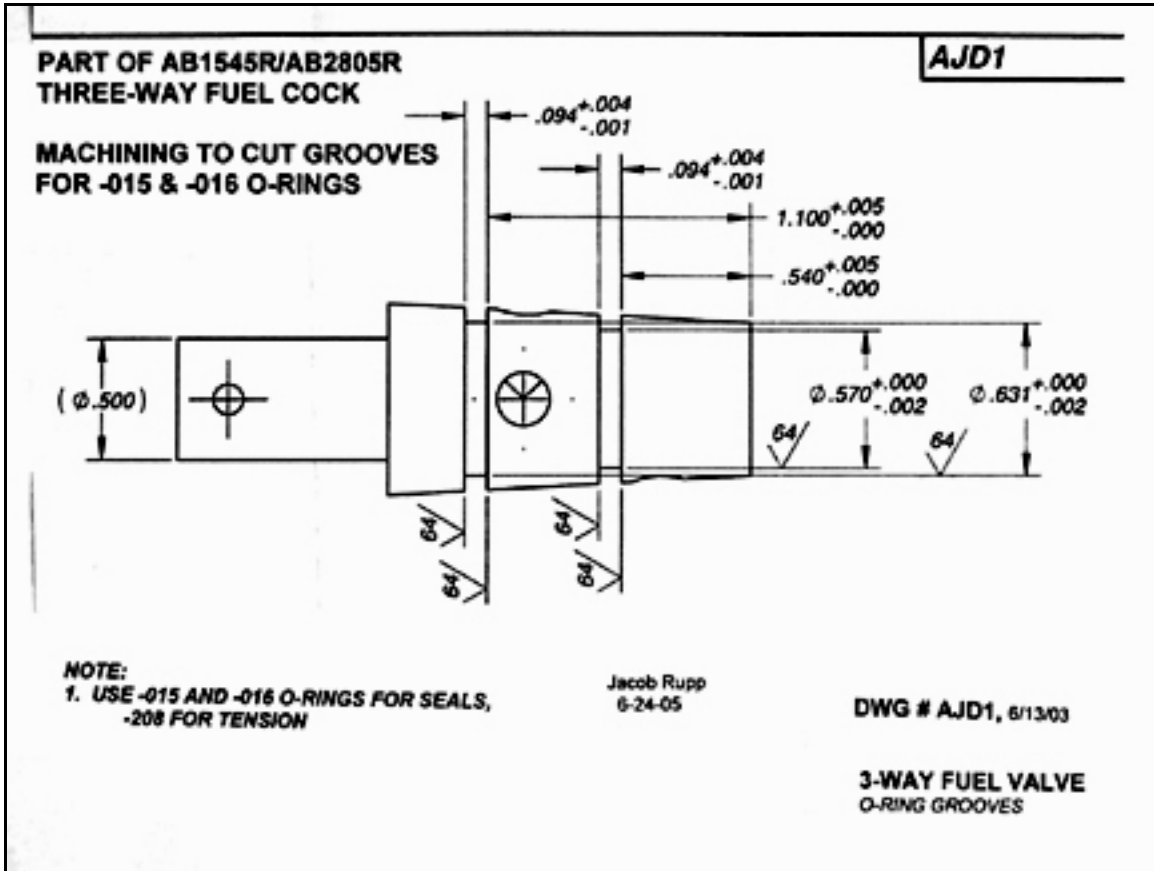

Engineering Drawing -- 3-Way Fuel Valve (By Jacob Rupp)

Here Jacob employs three O-Rings of AS 598A Standard Sizes -015 and -016 for seals and -208 for tension on the shaft under the nut. One could use the two smaller ones and D2122R packing in place of the -208 O-Ring just as well. In terms of ID/OD/Width of O-Ring, the AS 598A Standard sizes above translate as follows:

- 015 has an ID of 9/16 inch, OD of 11/16 inch, and width of 1/16 inch.
- 016 has an ID of 5/8 inch, OD of 3/4 inch, and width of 1/16 inch.
- 208 has an ID of 5/8 inch, OD of 7/8 inch, and width of 1/8 inch.

New Life for the Fuel Filter Assembly

Here we have the fuel shutoff portion of the original AA499R Fuel Filter Assembly. Note this is a "gate" type valve, with "tee-handle" vertical for "on," and horizontal for "off." With this gate valve, 1/4 turn is needed to go from ON to OFF, and vice versa. Over the years, the rotating part of the valve wears so that its fit is less than optimal, and the packing has become dried, shrunken and hardened after some 60 years on the job.



Figure 1(A&B). At left (A) we have AA499R without Glass bowl, depicting centered fuel tank fitting and with a pointer indicating the worn, hardened packing. On the right (B), we observe a sample of graphite packing commercially available at some hardware stores of a plumbing supply outlet.

~~ New Packing -- A499R Fuel Filter Assembly ~~

Cited below -- See an excerpt from one of those "do-it-yourself" websites for repairing a faucet that leaks. The technique is going to be very similar. As you will note, a "packing washer" (usually neoprene) is suggested as a possible replacement. This solution works well as you are able to simply unbolt the handle and have an uncluttered shaft to slide it down onto. This is not the case with AA499R.

In the case of the AA499R -- That brown, dried-up washer-looking donut is what remains of a six-decades-old packing made of "packing string". In the plumbing trade, it is known as

graphite packing -- comes in a variety of sizes. You may find it at a plumbing supply or at a Home Improvement Center in the plumbing department. You should obtain a fairly small size - one suitable for a small faucet or hose bib. Then, in accord with the underlined sentence in the excerpt below, renew the seal!

How much do you need? -- I believe I would install as much as I could get in and still start the packing nut onto its threaded region by two or three threads. You need as much as you can practically get in there, yet you also need to be able to get a good bite onto the casting with the packing nut so as to avoid a strip-out.

Excerpt -- Older faucets may use packing, usually a string like material that serves as a washer between the stem & the cap. Remove the old packing & wind new packing string clockwise around the stem to form the seal. If the older faucet uses self-forming packing, a ready-made packing washer that fits may be used as a replacement. Push the packing washer onto the stem as far as it will go & screw the nut over it, clockwise.

~~ John Deere Dealer Replacements ~~

If any of you went to your Deere dealer in search of a new AA499R Fuel Filter Assembly, you most likely come away with something different. JD literature shows AA5334R plus 29H598R close nipple as the suitable replacement. The problem is that the inlet fitting (top) of the AA5334R is offset from center by 1/2 inch which, in turn, forces the 3-way fuel cock 1/2 inch closer to the drip edge of the hood -- making wrench access to the packing nut of the 3-way fuel cock impossible on some models without cutting a notch in the hood! Thus, the motivation to save the old assembly becomes a higher priority than before!



Figure 2 (A&B). AA499R on the Left (A), AA5334R on the Right (B). Note Offset of roughly 1/2-inch off-center in AA5334R of tank fitting.

4-8-2010: In 2006, a direct replacement for AA499R became available from Steiner Tractor. Unfortunately, this was a near-perfect copy of the original from Deere – it also

would leak some! Old-timers will recall; the originals didn't do that well either! I now hear that Steiner is developing and replacement with a Gate Valve so as to do a better job! Watch for it soon! Go to their website of www.steinertractor.com. You may also call (810) 621-3000 and ask about the new & improved fuel filter to replace AA499R.

The O-Ring Solution -- for those more adept with machining, there follows a suggested solution to fuel leak problems (by Jacob Rupp) using rubber O-Rings as is outlined in Figure below.

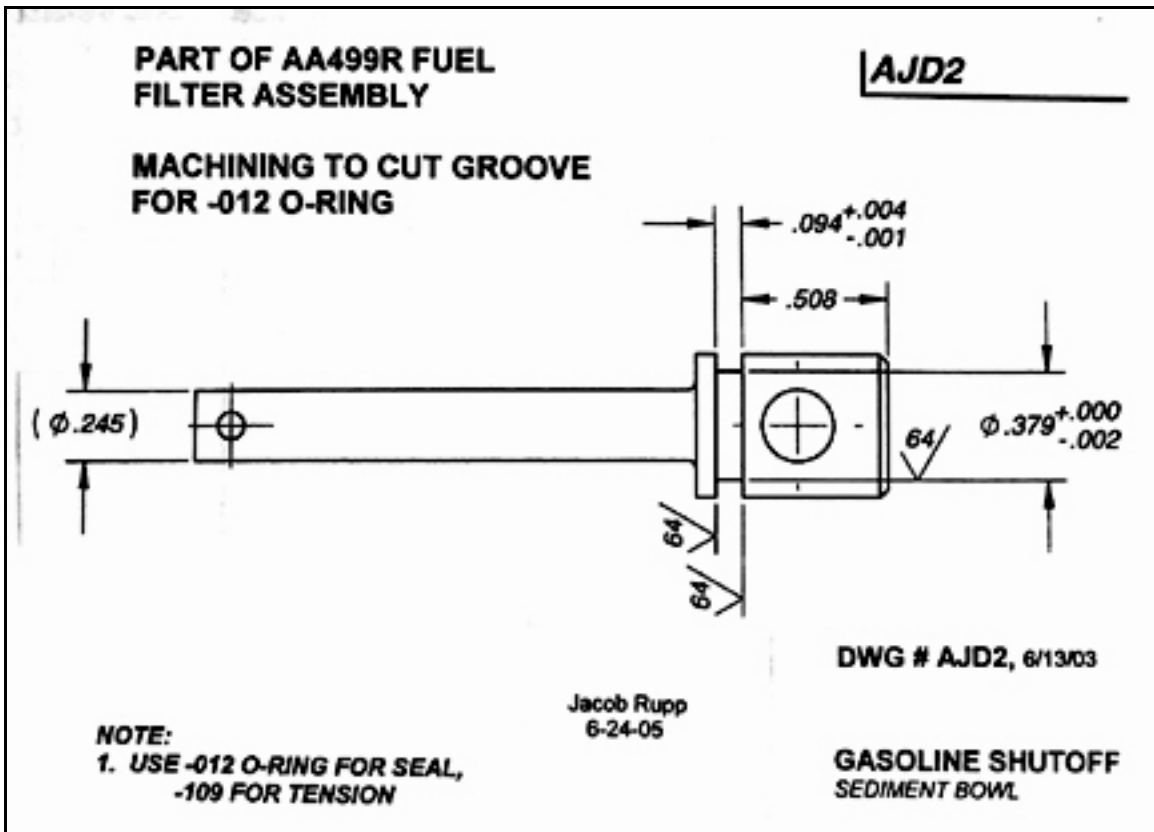

Figure 3. Engineering Drawing of Fuel Shut-off Valve (By Jacob Rupp)

Here Jacob employs two O-Rings of AS 598A Standard Sizes -012 for seal and -109 tension under the nut. One could also use graphite-impregnated packing fiber to reform what look like a brown donut on the shaft under the nut (see above). In terms of ID/OD/Width of O-Ring, the AS 598A Standard sizes above translate as follows:

-012 has an ID of 3/8 inch, OD of 1/2 inch, and width of 1/16 inch.

-109 has an ID of 5/16 inch, OD of 1/2 inch, and width of 3/32 inch. ++++

Carburetor Fuel Fitting & Fuel Line Installation

Terminology

Fuel inlet gland or outlet **gland** = the fittings soldered onto the fuel line
Fuel inlet nut/outlet **nut** = the clamping nuts on the fuel line

Shop Materials

Teflon tape, or
Plumbers Pipe Dope (preferred)
Thin Paper Gasket Material (1/64")

Tools

1/2" deep-well socket w/driver (install fuel inlet filter fitting)
1/2" Crowfoot wrench w/driver
11/16" open-end wrench

Discussion

Fuel leaks -- They are everyone's dread. And so we tend to try "tightness" as the ultimate fix -- with limited success. So many issues come into play with old tractor fuel systems. A few include: (1) tapped holes that are just a small bit enlarged from when new either from normal use over time, or having been chased too far with an NPT tap, (2) the mating parts are hardened and thus less malleable under pressure of being drawn together -- the glands may even be deformed, and (3) misalignment of fuel line glands (terminals) with designated fittings is always a clear & present concern.

Gasket -- A thin paper gasket added (in the fuel bowl) between the bowl and carburetor stem, i.e., to fit around the bowl nut, provides a very good seal between bowl and stem.

Fuel Filter Parts -- Another area of the fuel system prone to leakage is the sediment bowl. After 60 plus years of service, the adjusting nut or bail screw (AA518R) and bowl gasket (C1778R) generally merit outright renewal. In the PC304 Parts Catalog, see page 22, items 38 and 40. Direct replacements for these pieces & the bail can be found at Steiner Tractor (www.steinertractor.com), Steiner Part Numbers (STPs) ABC124 (Glass Bowl), ABC236 (Bail Assembly w/Brass Nut), JDS641 (Filter Screen), and JDS642 (Gasket).

Glands -- Replacement fuel inlet & outlet glands as well as both nuts are readily available, and if you observe any deformation of the gland mating surface, renewal is recommended. One source for these parts is Robert's Carburetor Repair (www.robertscarbrepair.com).

Concepts

The first is to realize that "gorilla wrenching" will generally fail to solve fuel leaking problems, and if it does (this time) you will have a devil of a time the next time you open and then close the joint.

A second is to realize we have some "compounding of fittings" in this system. That is, you tighten a fitting with sealant into its first mating fitting, and then you attach yet another fitting on top of this assembly of fittings. The threat here is disturbing the first joint while establishing the second one!

Techniques

Threaded fittings -- (1) Be absolutely certain the threads are as pure & straight as your eye can visualize. Use small triangle-shaped file (or a thread file) to remove burrs from male fittings, and plan on using new replacement nuts if there is ANY irregularities in nut threads. As in the case of fasteners designed to be tightened to a specified torque value, here also -- the fittings must turn without resistance all the way to their limit. (2) Use sealing compounds when bringing two parts together, threaded or swedged. I prefer plumbers' pipe dope to Teflon tape for fuel fittings. Basically, whatever compound you use should be soft and remain somewhat soft for a long time! Be liberal with pipe dope on fitting threads, but not enough so that globs of the compound end up in the fuel channel. Then bring the two together with "reasonable tightness". Recall that these are delicate fittings.

Swedged fittings -- Here I apply pipe dope to the clamping nut threads and to the threads of the fitting the nut runs up on, also to the end of the fuel line ferrule where it mates the other fitting, being careful here to prevent the compound from entering the fuel channel.

Cure Time -- Once assembled, I recommend an overnight set before applying fuel pressure to the lines.

Over-wrenching -- In accord with "threaded fittings" above, you have installed the fuel inlet filter with care and diligence. Now when installing the fuel line (per swedged fittings above), use the 1/2" Crowfoot wrench to hold the fuel inlet filter while tightening the fuel line clamping nut with the 11/16" open-end wrench.

TIP: Make note of the IDLE needle position and then rotate it out of the way if necessary, during fuel line installation.

TIP: A helper to hold the Crowfoot wrench while you tighten the fuel line may be wise.

For more information on history of the JD "H" tractor over its years of production, see my new book, **John Deere Model "H" Restoration Guide**. Go to Home Page to order.